

Installation & Operating Instructions



Universal Remote Emergency Pack

For use with LED Modules only

Product Specification

| | |
|---|-----------------------|
| - Mains voltage: | 230V +/- 10% |
| - Mains frequency: | 50 - 60Hz |
| - Power Consumption (Excluding external Driver): | 4VA |
| - 2 x user-serviceable internal fuses: | 'T' 2A 5x20mm |
| - Emergency output voltage range: | (See product label) |
| - Emergency Duration: | (See product label) |
| - Battery: | (See product label) |
| - Ambient temperature range: | +5°C to +35°C |
| - Min/Max Conductor sizes: | 0.5-4mm ² |
| - Weight | 0.7kg |
| - Charging time: | 24 hours |
| - Protection class: | 1 |
| - Degree of protection: | IP20 |
| - Material: | UL94 V0 Polycarbonate |
| - Em module complies with: | BS EN 61347-2-7/2-13 |
| - Suitable for installation to EN50172 and BS7671 | |

The unit provides reinforced insulation between the mains supply and battery charging circuit and employs self-resetting protection against short-circuit of battery terminals. Normal charging will resume automatically once a fault is removed.

Emergency Lighting 'standard' or 'manual' Test

The following minimum inspections and tests should be carried out:

Monthly

Switch off the mains power supply to the lighting unit. Inspect all emergency lights for satisfactory operation. Any defects should be noted and actioned by a competent person as soon as possible.

Yearly

Switch off the mains power supply to the lighting unit. Leave the unit to run for the rated period (e.g. three hours). The lights should remain operable from the battery for the whole period.

Please be aware that further inspection / testing may be required, e.g. by risk assessment / local legislation.

Batteries and Disposal

The internal battery has a design life of 4 years and must be replaced in a timely manner to ensure the integrity of the emergency lighting system is maintained. In any case, the battery should be replaced when it no longer provides the rated duration (3 hours).

The manufacturer of the enclosure is committed to fulfil its obligations as a producer of batteries used in emergency lighting applications. End-of-life batteries may be returned to the remote enclosure manufacturer at the customer's cost and arrangements will be made to ensure their correct disposal. Alternatively, they may be returned directly to an authorized treatment facility at the customer's cost.

NOTE – To comply with regulations, installation must be carried out by a suitably qualified, competent person and in accordance with the current IEE wiring regulations (BS7671) and building regulations. The emergency pack requires 2 live feeds, a permanent supply for charging the battery pack and 1 for switching the lamp on and off.

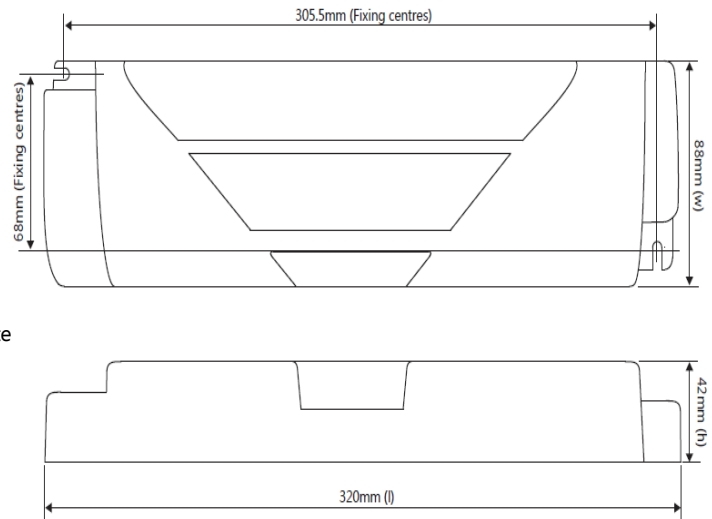

Features

- > For use with LED panels, arrays or down lights of compatible voltage.
- > External battery connector for simple isolation
- > 3-pole isolation of lamp & mains driver power during emergency
- > Contains replaceable 4Ah Nickel Cadmium (NiCd) or 4Ah Nickel Metal Hydride (NiMH) battery (See product label)
- > Emergency output power (Typical) : 3W (3-cell) and 4W (4-cell)
- > 1 or 3-hour autonomy (See product label)
- > Battery connectors are polarity protected

Installation

Ensure the mains supply is isolated before attempting installation!

Please refer to page 2 of this leaflet for mains supply, driver and lamp connections. Once wiring is complete, use both internal cable clamps to secure cables in place. To prevent unauthorised access, ensure the lid is fixed in place using the screw on the base. If external plug and socket connectors are used without means to prevent accidental disconnection, the remote box should be sited so that it is protected from unauthorised disconnection.

A recessed mount can be found inside the packaging carton to assist installation of the indicator LED. A 14-16mm hole should be drilled in the required location so it is visible during normal use.

Once installed, the indicator LED will be illuminated and the supply should be left undisturbed for a minimum of 24 hours to charge the batteries before attempting a commissioning test. After a successful test, the date should be noted on the space provided on the battery.

Standard / single colour (green) shows the following condition:

A green LED shows the following conditions:

- LED green: mains OK and battery connected
- LED off: Mains failure [below 160V], battery disconnected/ battery faulty or faulty unit.

Installation & Operating Instructions

Wiring information

Non-Maintained application without connectors

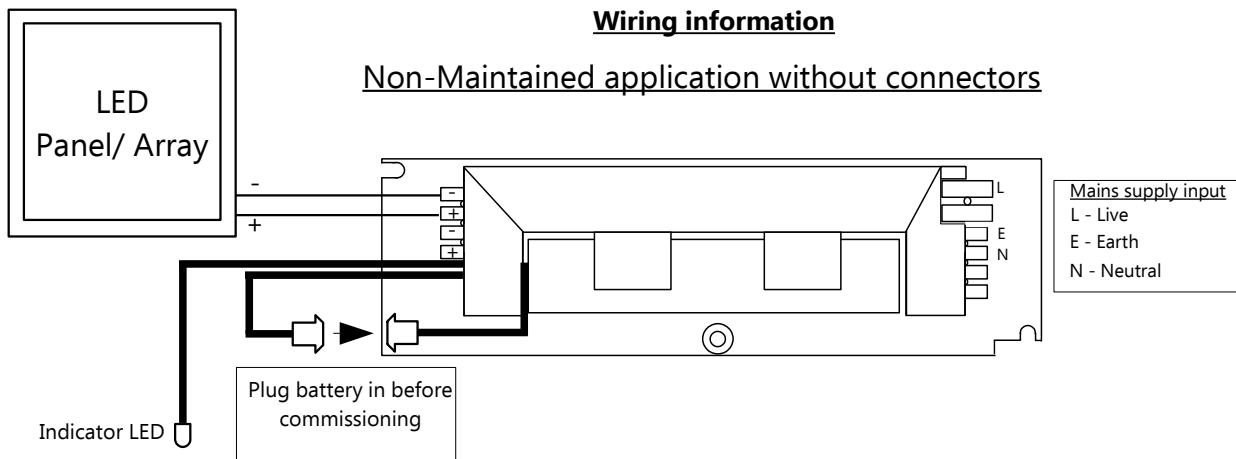

Maintained application without connectors

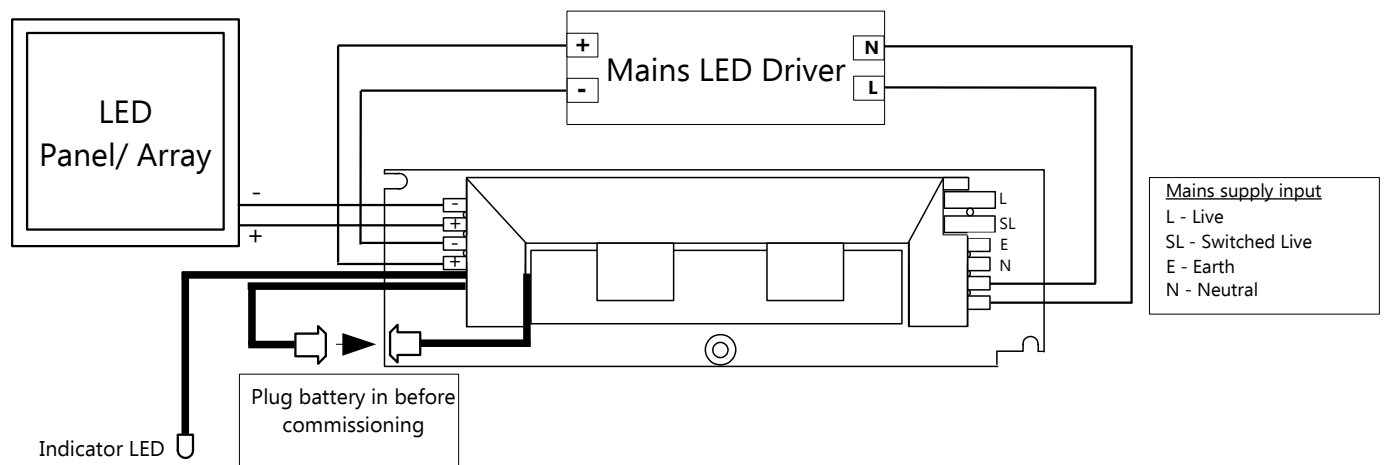

Maintained application with connectors

